

Edger Optimizer Technology

DK 90



Manual fed edger and gang circular resaw



**EWD**  
The SawLine Company™

## Manual fed edger and gang circular resaw

with bottom arbor and up to 4 hydraulically variable moveable saw heads for edging and resawing of boards and cants



Clear pointers indicate the position of the saw heads and the pickers at the machine. Perfect board alignment by means of moveable laser lines.

The manual fed edger and gang circular resaw DK 90 is the perfect supplement to main break down machines such as sash gang saw or log bandmill in small and medium sized sawmills. In larger operations the DK 90 is used as a valuable side machine for versatile and flexible tasks.

The machine was refined over many years and stands today for high and everlasting reliability also under tough conditions.



Good accessibility for the tool change



① Operator terminal for input of the edging programs and graphical display of machinery conditions and fault alarms in plain language.

② Infeed system RKB for heavy lumber, consisting of:

- Roller table
- Lift/lowering alignment chain
- Chain bed with additional press roller

③ Laser lines

④ DK 90 edger and gang circular resaw

⑤ Edging separator

Saw set distances (in mm)

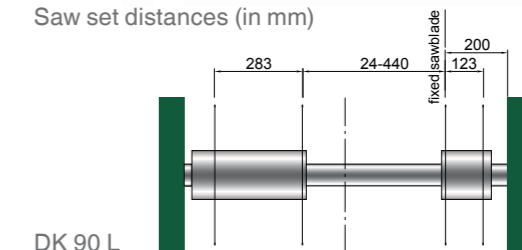

DK 90 L

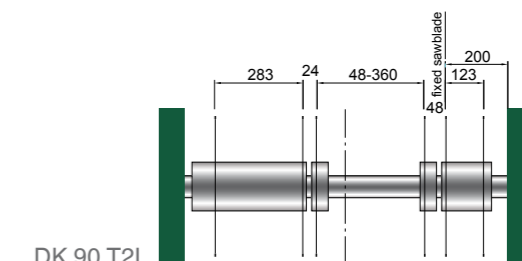

DK 90 T2L

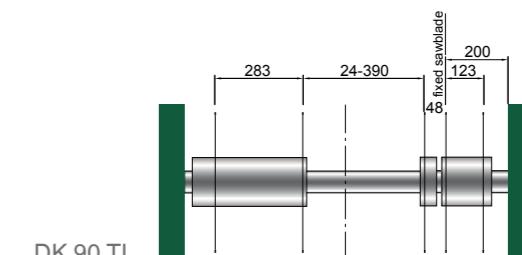

DK 90 TL

Saw heads are positioned with hydraulic cylinders and maintenance-free sensors.

## Technical data

Type	DK 90	
Sawing height*	mm	15 – 120 (*Special unit: 160 mm)
Lumber length min.	m	1
Lumber width unedged	mm	80 – 900 (700)
Lumber width edged	mm	24 – 600
Machine opening max.	mm	1000 (800)
Saw blade diameter max.	mm	500
Saw arbor diameter	mm	70
Main drive motor size	kW	37 – 132 (@ 3000 rpm)
Feed drive motor	kW	5,5 – 7,5
Feed speed max.	m/min	100
Weight without drive motor	t	approx. 4,5
Weight with drive motor (90 kW)	t	approx. 5,0

### Dimensions (in mm)

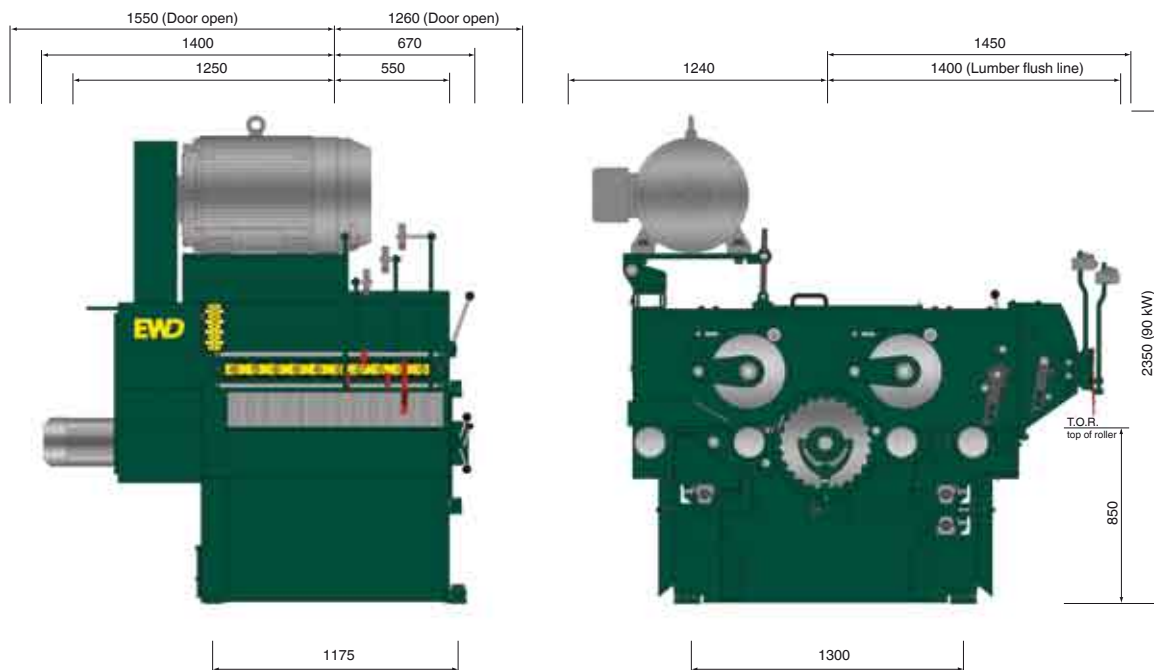

Due to constant product improvements or developments the illustrations and specifications contained in this brochure are subject to change without notice.